

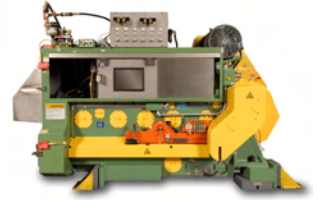

Air Bag Retrofit

For the Stolle Ragsdale Bodymaker
May 2007



Stolle Machinery has developed an air bag assembly for Stolle Ragsdale Bodymaker redraw assembly that is a lower cost / lower maintenance alternative to the existing air cylinder assembly. This air bag retrofit is only for bodymakers running at less than 300 SPM as higher speeds can result in overheating and reduced service life. The cost of the replacement air bag is about \$250 as compared to \$6000-\$7000 to rebuild the air cylinder assembly. The air bag does not require cooling water, has no air gap to set, and eliminates some of the lubrication requirements.

Stolle recommends replacing the air bag every 3 to 6 months, depending on the bodymaker coolant and plant ambient temperature conditions. The replacement procedure is a light one-man job that takes about 45 minutes, as opposed to 6 to 8 hours to replace an air cylinder. If the airbag were to fail without warning at bodymaker operating speed, significant damage to the cam assembly can occur. The air bag retrofit kit includes an electronic pressure switch that will immediately stop the bodymaker in event of an air bag failure.

Please contact Stolle CMD at 303-708-9044 for pricing and lead time on the air bag retrofit package - part number 222001430.

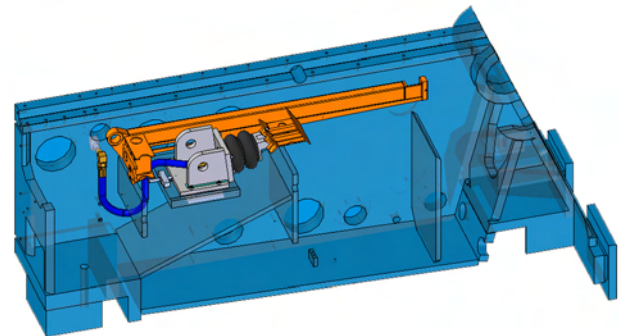
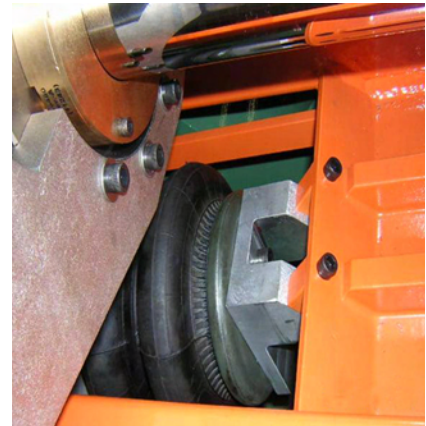

See following page for section drawings of air bag assembly with part numbers





Stolle Ragsdale Bodymaker Redraw Assembly
Air Bag Retrofit - Part number 222001430

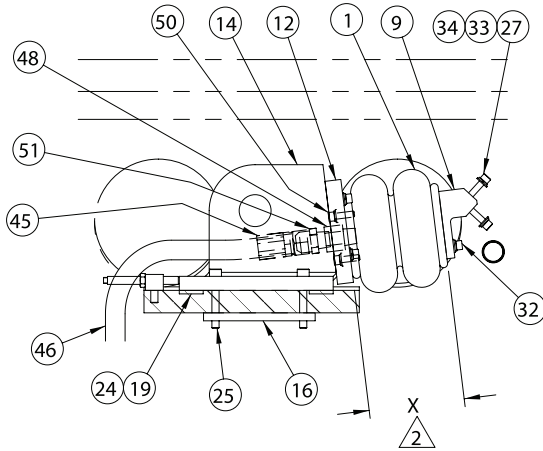

2 SEE WATER & AIR CNTRL AY.

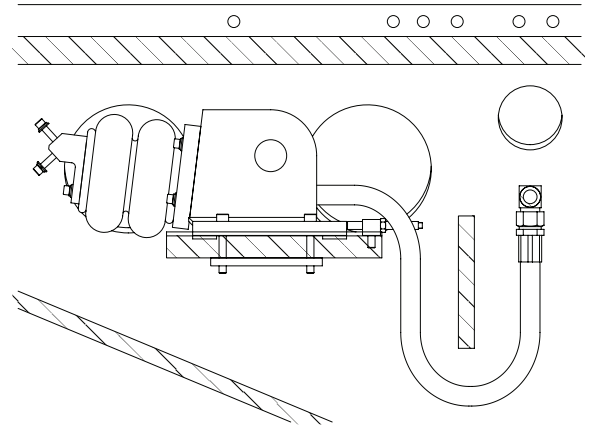
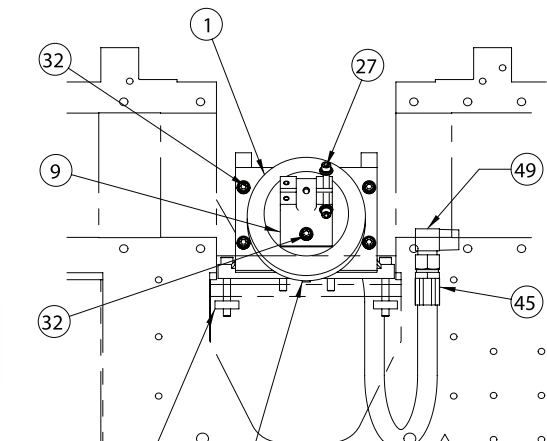
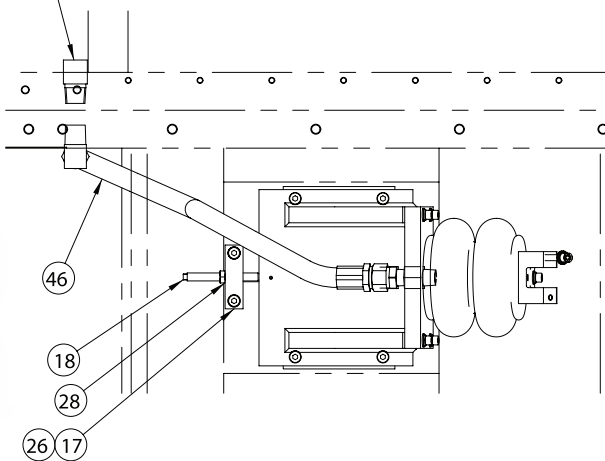

NOTES:

1. HOSE CUT LENGTH MAY BE REVISED IN FIELD IF REQUIRED.
2. SEE TABLE FOR SET-UP DIMENSION.

Item	QTY	PART NO.	DESCRIPTION
1	1	222001461	AIR BAG
2	1	101864	ELBOW, SURGE TANK
9	1	222001460	CLEVIS, AIR BAG
12	1	222001462	PLATE, MOUNT, AIR BAG
14	1	222001463	MACHINING, TRUNION MOUNT,
16	2	114187	NUT, TANDEM, AIR SPRING CYLINDER
17	1	114772	SPRING AIR ADJ BLOCK
18	1	114836	STUD, ADJUSTING .50-20
19	2	114786	KEY, TRUNION MOUNT
24	2	741120	SHCS, 10-32 X .75
25	4	742410	SHCS, .500-13 X 3.25
26	2	742470	SHCS, .500-20 X 1.25
27	2	741960	SHCS, .375-16 X 1.750
28	1	752800	NUT, JAM .500-20
32	5	741990	SHCS 3/8-16 UNC-2A X 2.25" LG.
33*	9	750120	WASHER, FLAT PLATED, Ø.375
34	9	750054	WASHER, 3/8 LOCK
45	2	730413	FITTING, AQ 4411-16
46	4	739080	HOSE, AEROQUIP FC350-16
48	1	701779	FITTING, 3/4FPT X 3/4MPT
49	1	730640	FITTING, 90° 1" MNPT X 1" 37° FLARE
50	2	741940	SHCS, .375-16 X 1.250
51	1	738810	FITTING, 3/4" MNPT X 1" 37° FLARE



Stolle Machinery Company - Can Machinery Division
 6949 South Potomac Street, Centennial, CO 80112
 Phone: 303-708-9044 Fax: 303-708-9045
 www.stollemachinery.com

Copyright 2007 Stolle Machinery Company, All Rights Reserved



Systems Spares Service Support

StollePlus
For The Life of Your Equipment