



## **Mandrel Arm Upgrades**

For Stolle Concord Decorator - 36 and 24 rotary trip mandrel machines  
September 2007



Stolle Machinery has made improvements on two components of the rotary trip mandrel system for Stolle Concord Decorators. These retrofits can be installed by the can plant's maintenance personnel; however Stolle CMD's service technicians would be available at the standard service rates.

The first is a **steel mandrel arm** that replaces the previous aluminum arms. These new forged steel arms are more robust and fatigue resistant than the previous aluminum arms, resulting in longer life and lower maintenance costs. The steel arms would also have less deflection and will allow less mandrel-to-blanket pressure (print pressure) which results in higher print quality.

The new steel mandrel arms are now standard on all 36MRT and 24MRT (mandrel rotary trip) machines, and are available as a retrofit for existing MRT machines (not for existing interposer type machines, these would require a complete 24MRT retrofit). The arms can be purchased as a complete assembly, or the steel mandrel arm only. Installation of the steel mandrel arm assemblies will take apx. 12 hours on a 36 mandrel decorator including completing the mandrel circle, and apx. 8 hours on a 24 mandrel decorator including completing the mandrel circle.

The part numbers below are for both the 24MRT and the 36MRT Stolle Concord Decorator and Base Coater machines:

309969 – Steel mandrel arm assembly

309970 – Steel mandrel arm only

NOTE: This would require off-line assembly time of 14 hours prior to installation for a 36MRT machine, and 10 hours off-line assembly time for a 24MRT machine.

Please contact Stolle CMD at 303-708-9044 for pricing and lead time on the steel mandrel arms and assemblies.

*Continued on next page*

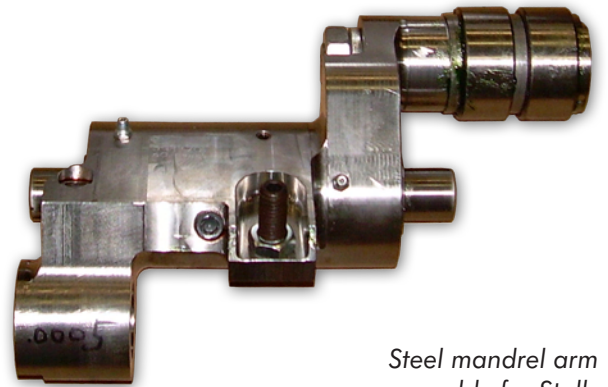

*Steel mandrel arm assembly for Stolle Concord 36 and 24 mandrel rotary trip decorators and base coaters*

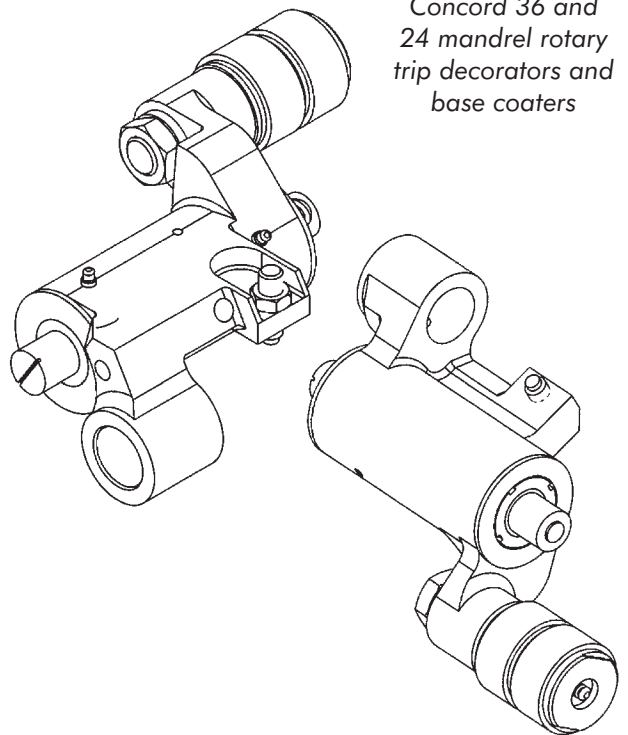



The second component is a **rotary trip arm spring** that replaces previous air cylinders on 36 and 24 mandrel Concord Decorators. The new rotary trip arm springs are more reliable than the air cylinders, also resulting in longer life and lower maintenance costs. The springs effectively keep the mandrel arms in the desired mandrel circle as the centrifugal forces increase during the highest machine speeds.

The rotary trip arm springs are standard on new 36 and 24 mandrel decorators, and are available as a retrofit for existing machines. Installation time for the 36 mandrel decorator spring kit is apx. 10 hours, and apx. 8 hours for the 24 mandrel decorator spring kit.

The part numbers below are for both the 36MRT and the 24MRT Stolle Concord Decorator:

222015266 – 36 mandrel decorator spring kit  
(1 each required)

222010333 – 24 mandrel decorator spring kit  
(24 each required)

Please contact Stolle CMD at 303-708-9044 for pricing and lead time on the rotary trip arm spring kits.

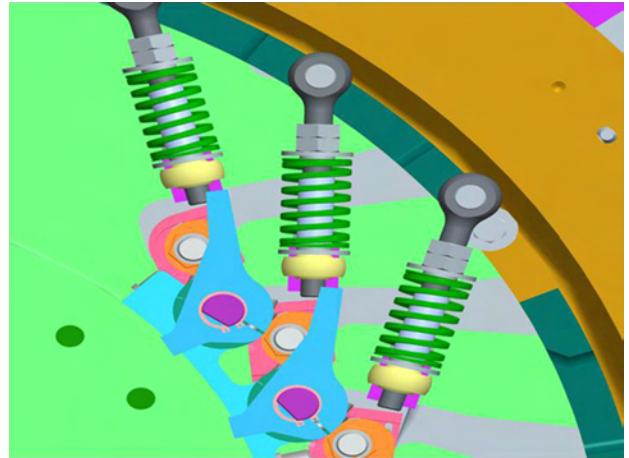

*Model of rotary trip arm springs installed on Stolle Concord Decorator mandrel*

